

# Guidance and Control Technology

**Erik Berglund**

Swedish Defence Research Agency  
172 90 Stockholm, Sweden  
eberglund@foi.se

## Summary

The fundamental ideas and the basic mathematics of the most common missile guidance laws are outlined. Rules of thumb for the required lateral acceleration for the different guidance laws are given.

A brief summary of flight mechanics is given. The pitch axis control is treated and the dynamic properties are identified. Design of the autopilot for the inner loop using modern methods of controller design is briefly outlined.

## Introduction

Precision guided weapons have played an increasingly important role in recent conflicts and much media attention has been focused on the surgical precision provided by modern high-tech weapons. However, the concepts behind today's guided weapons date back to the Second World War and in some cases even to the First World War. It is, however, clear that the technological progress has only recently made it possible to fully exploit the concept of guided weapons.

*Guidance* can be defined as the strategy for how to steer the missile to intercept, while *control* can be defined as the tactics of using the missile control actuators to implement the strategy.

Guidance has normally been divided into:

- Target related guidance, where target tracking data are provided in real time from a sensor, which can be on-board or off-board.
- Non-target related guidance, where the missile navigates to some predetermined point, which can be the target or the point where target related guidance can begin.

As the integration sensor-to-shooter improves and near real time targeting data can be obtained from sensors not tied to the missile system, this distinction becomes less clear. It must also be noted that the performance of affordable navigational systems (integrated GPS/INS) offers precision in the order of meters. Weapons using non-target related guidance, such as JDAM, can hence compete with traditional homing missiles.

## Mid-course guidance and trajectory optimisation

A case of partially target related guidance is mid-course guidance, where the missile is guided to the vicinity of the target using target data from an external sensor. Most long range weapons designed against mobile targets employ mid-course guidance. Examples of this are air-to-air missiles such as AMRAAM.

Air-to-air missiles often employ trajectory optimisation during the mid-course. The main reason for this is to exploit the lower drag at higher altitude. Optimisation can be used to obtain minimal time of flight, maximal range, maximal terminal velocity etc.

Trajectory optimisation can also be used for air-to-surface weapons to obtain a favourable angle of impact, no angle of attack at impact etc. The performance of penetrating warheads can be greatly improved by terminal trajectory optimisation.

A further use for trajectory optimisation can also be route planning, where the missile's flight path is planned to avoid obstacles, maximise survivability, maximise the probability of target acquisition etc. This planning is normally done prior to launch, but re-planning can be done in flight by the missile.

Advances in computational power and optimisation algorithms have now made it possible to use real time optimisation in flight.

## Guidance Laws

The most fundamental, and also most commonly used, guidance laws are:

- Velocity Pursuit
- Proportional Navigation
- Command-to-Line-of-Sight
- Beam Riding

All of these guidance laws date back to the very first guided missiles developed in the 1940's and 1950's. The reasons that they have been so successful are mainly that they are simple to implement and that they give robust performance.

Velocity pursuit is used mainly in the first generations of laser guided bombs, e.g. Paveway I and II. Proportional navigation is used in almost all homing missiles. Command-to-line-of-sight is used in short to medium range missiles without seekers, e.g. most anti-tank missiles and many surface-to-air missiles. Beam-riding is not so common, but it is found in surface-to-air missiles such as RBS70 and ADATS.

The presentation in this paper is mainly based on Assarsson. For further reading on missile guidance there are several good textbooks, e.g. Blakelock, Garnell, Lee, and Zarchan.

## Velocity Pursuit

The conceptual idea behind velocity pursuit guidance is that the missile should always head for the targets current position. Provided that the missile's velocity is greater than the target's, this strategy will result in an intercept.

The required information for velocity pursuit is limited to the bearing to the target, which can be obtained from a simple seeker, and the direction of the missile's velocity. Velocity pursuit is usually implemented in laser guided bombs, where a simple seeker is mounted on a vane, which automatically aligns with the missile's velocity vector relative to the wind. The mission of the guidance and control system thus becomes to steer the bomb such that the target is centred in the seeker.

Using a target fixed polar coordinate system, see figure 1, the equations describing the kinematics of velocity pursuit are

$$\begin{aligned}\dot{r} &= v_T \cdot \cos \phi - v_M \\ r \cdot \dot{\phi} &= -v_T \cdot \sin \phi\end{aligned}$$

Integration gives

$$r = r_0 \cdot \frac{(1 + \cos \phi_0)^{\frac{v_M}{v_T}}}{(\sin \phi_0)^{\frac{v_M}{v_T}}} \cdot \frac{(\sin \phi)^{\frac{v_M}{v_T}-1}}{(1 + \cos \phi)^{\frac{v_M}{v_T}}}$$

where index 0 denotes the initial condition.

An observation from the above equation is that intercept (when  $r$  approaches zero) occurs at either  $\phi=0$  or  $\phi=\pi$ , i.e. tail-chase or head-on. As the head-on case proves to be unstable, the only feasible case is the tail-chase intercept.

The velocity pursuit guidance law results in high demanded lateral acceleration, in most cases infinite at the final phase of the intercept. As the missile cannot perform infinite acceleration, the result is a finite miss distance.

Velocity pursuit is thus sensitive to target velocity and also to disturbances such as wind. The velocity pursuit guidance law is not suitable for meter precision.

## Proportional Navigation

The conceptual idea behind proportional navigation is that the missile should keep a constant bearing to the target at all time. As most sailors know this strategy will result in an eventual impact.

The guidance law that is used to implement this concept is

$$\dot{\gamma} = c \cdot \dot{\phi}$$

where  $\gamma$  is the direction of the missile's velocity vector,  $\phi$  is the bearing missile to target, and  $c$  is a constant. Both of the angles  $\gamma$  and  $\phi$  are measured relative to some fixed reference.

With angles as defined in figure 4 and using polar coordinates the following kinematic equations in the 2D case can be obtained:

$$\begin{aligned} r\dot{\phi} &= v_M \cdot \sin(\phi - \gamma) - v_T \cdot \sin \phi \\ \dot{r} &= -v_M \cdot \cos(\phi - \gamma) + v_T \cdot \cos \phi \\ \dot{\gamma} &= c \cdot \dot{\phi} \end{aligned}$$

A linearised model of the kinematics can be obtained by considering deviations denoted by  $\Delta$  from the ideal collision triangle denoted by index 0.

$$\begin{aligned} \phi &= \phi_0 + \Delta\phi \\ \gamma &= \gamma_0 + \Delta\gamma \\ \gamma_T &= \gamma_{T0} + \Delta\gamma_T \end{aligned}$$

where  $\gamma_T$  is the direction of the target's velocity vector relative to the reference.

The equations for the disturbances thus become:

$$\begin{aligned} \frac{d}{dt}(\Delta\phi \cdot r) &= -v_M \cdot \cos(\phi_0 - \gamma_0) \cdot \Delta\gamma + \\ &+ v_T \cdot \cos(\phi_0 - \gamma_{T0}) \cdot \Delta\gamma_T \\ \dot{r} &= -v_M \cdot \cos(\phi_0 - \gamma_0) + v_T \cdot \cos(\phi_0 - \gamma_{T0}) \approx -v_C \\ \frac{d}{dt}(\Delta\gamma) &= c \cdot \frac{d}{dt}(\Delta\phi) \end{aligned}$$

where the closing velocity  $v_c$  has been introduced.

The time-to-go,  $\tau$ , is introduced as

$$\tau = \frac{r}{v_c}.$$

From the equations can be observed that

$$\dot{\gamma} = -\frac{c \cdot v_M \cdot \cos \phi_0}{\tau \cdot v_c} \cdot \gamma + \dots$$

It can be concluded that the factor

$$\frac{c \cdot v_M \cdot \cos \phi_0}{\tau \cdot v_c}$$

is of significant importance to the performance of the guidance law.

So far the guidance law has been formulated with the rotation of the velocity vector as the variable to be controlled. However, a more natural variable to control is the missile's lateral acceleration. As the closing velocity, which is found in the loop gain above, varies greatly with the geometry of the intercept, altitude, target type etc, it is desirable to include the closing velocity in the guidance law.

Hence

$$n_M = \alpha \cdot v_c \cdot \dot{\phi}$$

The parameter  $\alpha$  is called the navigation constant and should be between 3 and 4 (maybe up to 5) to ensure good dynamic performance. A value of  $\alpha$  greater than 2 is required for the missile to intercept manoeuvring targets.

This formulation requires a measurement or an estimate of the closing velocity. If the missile uses active radar homing, a measurement of the closing velocity can be obtained using Doppler technology. In most other cases a rough estimate can be obtained from the geometry of the engagement and the altitude.

From the equations above an expression for the required missile acceleration to intercept a manoeuvring target can be derived as:

$$\frac{n_M}{n_T} = \frac{\cos \phi_0}{\cos(\phi_0 - \gamma_0)} \cdot \frac{\alpha}{\alpha - 2} \cdot \left[ 1 - \left( \frac{\tau}{\tau_0} \right)^{\alpha - 2} \right]$$

Where  $\tau_0$  has been introduced as the total time of flight and  $n_T$  is the target load factor. In the head on or tail chase scenarios this can be simplified and especially if the endgame, where  $\tau$  approaches zero, is considered, the following expression is obtained:

$$\left| \frac{n_M}{n_T} \right| = \frac{\alpha}{\alpha - 2}$$

As  $\alpha$  normally is between 3 and 4, this rule of thumb gives that a homing missile should be designed to perform three times the target's possible lateral acceleration.

## Augmented Proportional Navigation

The proportional navigation guidance law gives the missile good performance against targets moving with constant velocity. If the target acceleration can be measured, it is possible to augment the PN guidance law by adding a term to compensate for the target acceleration. The Augmented Proportional Navigation (APN) guidance law thus becomes

$$n_M = \alpha \cdot \left( v_c \cdot \dot{\phi} + \frac{1}{2} \cdot n_T \right)$$

For APN the required lateral acceleration of the missile given by a target manoeuvre can be derived as

$$\frac{n_M}{n_T} = \frac{1}{2} \cdot \alpha \left( \frac{\tau}{\tau_0} \right)^{\alpha-2}$$

The maximal acceleration thus becomes

$$\frac{n_M}{n_T} = \frac{1}{2} \cdot \alpha$$

Or, as  $\alpha$  is between 3 and 5, about twice the target load factor. It can furthermore be observed that the maximal acceleration occurs at the initiation of the evasive manoeuvre, while for the PN law it occurs at the more critical final phase of the intercept.

However, before declaring the augmented proportional navigation law as superior to PN, the dynamic performance and the robustness relative to disturbances have to be considered.

The missile is here assumed to be a third order system, i.e.

$$\frac{n_M}{n_c} = \frac{1}{(1+sT) \cdot \left( 1 + \frac{2\zeta s}{\omega} + \frac{s^2}{\omega^2} \right)}$$

with the following numerical values:

$$\begin{aligned} \omega &= 10 \text{ rad / s} \\ \zeta &= 0.7 \\ T &= 0.5 \text{ s} \end{aligned}$$

The missile furthermore has a navigational constant of 3 and the target manoeuvres with a load factor of 3g. Then the miss distance as function of time to go at the initiation of the target manoeuvre and of the accuracy with which the target's acceleration can be estimated is shown in figure 5.

The conclusion from the dynamic analysis of the APN law is that the superior performance relative to PN is clearly sensitive to errors in the estimation of the target manoeuvre. It can also be noted that it is especially bad to over estimate the target acceleration. This sensitivity is certainly a reason for the limitations faced by APN in practical use.

## Command-to-Line-of-Sight and Beam Riding

Both Command-to-Line-of-Sight (CLOS) and Beam Riding (BR) use the same fundamental idea, i.e. that the missile should be on the straight line between the launcher and the target throughout the trajectory. That guidance law can be called line-of-sight guidance or three point guidance.

With terminology according to figure 6 and with  $r_M$  and  $r_T$  the distances from the missile fire unit to the missile and to the target respectively, the equations describing line-of-sight guidance can be expressed in polar coordinates as:

$$\begin{aligned} r_M \cdot \dot{\phi}_M &= -v_M \cdot \sin(\phi_M - \gamma_M) \\ \dot{r}_M &= v_M \cdot \cos(\phi_M - \gamma_M) \end{aligned}$$

If the first equation is derived with respect to the time and divided by the second, the following equation is obtained:

$$\dot{\gamma}_M = \left( 2 - \frac{\dot{v}_M}{v_M} \cdot \frac{r_M}{\dot{r}_M} \right) \cdot \dot{\phi}_M + \frac{r_M}{\dot{r}_M} \cdot \ddot{\phi}_M$$

The equation for the target can be expressed similarly as

$$\dot{\gamma}_T = \left( 2 - \frac{\dot{v}_T}{v_T} \cdot \frac{r_T}{\dot{r}_T} \right) \cdot \dot{\phi}_T + \frac{r_T}{\dot{r}_T} \cdot \ddot{\phi}_T$$

Ideal line-of-sight guidance implies that

$$\phi_M \equiv \phi_T$$

The missile equation can thus be written as

$$\dot{\gamma}_M = \left( 2 - \frac{\dot{v}_M}{v_M} \cdot \frac{r_M}{\dot{r}_M} \right) \cdot \dot{\phi}_T + \frac{r_M}{\dot{r}_M} \cdot \left[ \frac{\dot{r}_T}{r_T} \cdot \dot{\gamma}_T - \left( 2 \frac{\dot{r}_T}{r_T} - \frac{\dot{v}_T}{v_T} \right) \cdot \dot{\phi}_T \right]$$

If

$$\begin{aligned} \dot{v}_T &= 0 \\ \dot{v}_M &= 0 \end{aligned}$$

i.e. constant velocity is assumed for both missile and target, the equation becomes

$$\dot{\gamma}_M = \left( 2 - \frac{r_M}{\dot{r}_M} \cdot \frac{\dot{r}_T}{r_T} \right) \cdot \dot{\phi}_T + \frac{r_M}{\dot{r}_M} \cdot \frac{\dot{r}_T}{r_T} \cdot \dot{\gamma}_T$$

The first term in this equation gives the manoeuvre required for the missile to keep up with the rotation of the line-of-sight, while the second term gives the manoeuvre required to counter a target manoeuvre. An analysis of the second term, using the facts that the missile generally is between the launcher and the target and also generally moving away from the launcher with greater velocity than the target, i.e.

$$\begin{aligned} r_M &< r_T \\ \dot{r}_M &> \dot{r}_T \end{aligned}$$

shows that the manoeuvrability requirement generated by target manoeuvres is less than the target load factor and that it increases closer to intercept. This is in contrast to the manoeuvre requirement for proportional navigation which is about three times the target load factor.

The dominating manoeuvrability requirement on line-of-sight guided missiles is usually not generated by target manoeuvres but by target velocity. The requirement for a short inner limit to the launch zone is often the driving requirement.

The required lateral acceleration can be expressed as

$$n_M = 2 \frac{v_M \cdot v_T}{d} \beta$$

where  $\beta$  is an acceleration factor obtained from the diagram in figure 8.  $d$  is the crossrange, i.e. the minimal perpendicular distance between the target's trajectory and the fire unit, and  $\varphi$  is angle between the line-of-sight and the missile velocity vector.

Both CLOS and BR rely on a tracking sensor in connection to the launcher to track the target continuously during the intercept. In a CLOS system the tracking sensor tracks both the target and the missile and measures the angular difference between the two objects. Control commands are then calculated based on the desire to drive the angular difference between the missile and the target to zero, and these commands are subsequently transmitted to the missile.

In a beamrider system the fire unit projects a beam that continuously tracks the target. This beam can be generated by a laser or by an RF transmitter. The missile has a sensor in its rear, that measures the deviation from the centre of the beam and the missile flight control system seeks to minimise that deviation.

Although the guidance law is the same for CLOS and BR, the former implementation enjoys an advantage as the calculation of the command signals can use more information than just the present deviation from the line-of-sight. The use of the rotation of the line-of-sight as a feed-forward term can significantly decrease the miss distance.

Both CLOS and BR are limited in range, as the target tracking errors, which are the results of angular measurements at the launch site, generate miss distances proportional to the range.

## Characteristics of the Guidance Laws

The characteristics of the treated guidance laws are summarised in the table below.

| Guid.law | Acc due to target velocity | Acc due to target acceleration | Required measurement                                  |
|----------|----------------------------|--------------------------------|---|
| VP       | infinite                   | infinite                       | Angle between target bearing and velocity vector      |
| PN       | Zero                       | $3 * n_T$                      | Rotation of bearing to target                         |
| APN      | Zero                       | $2 * n_T$                      | Rotation of bearing to target and target acceleration |
| CLOS     | High at short range        | $< n_T$                        | Angular deviation from line-of-sight                  |
| BR       | High at short range        | $< n_T$                        | Angular deviation from line-of-sight                  |

## Control

An autopilot is a function that improves the flight performance of the vehicle by using feed-back of some of the state variables, such as angular velocities and accelerations, obtained from rate gyros and accelerometers respectively.

The mission of the control system in the missile autopilot is to ensure stability, high performance, and that the missile flies in accordance to the demands from the guidance law. The most important objective is to design the control system such that the miss distance is minimised given relevant disturbances such as target evasive manoeuvres, measurement noise, jamming, wind etc.

The missile dynamics to be controlled are given by Newton's equation for a rigid body in 6 degrees of freedom:

$$\sum \mathbf{F} = \frac{d}{dt}(m\mathbf{v})$$

$$\sum \mathbf{M} = \frac{d\mathbf{H}}{dt}$$

Or explicitly as six equations, and with the assumption of constant mass:

$$F_x = m(\dot{u} + wq - vr)$$

$$F_y = m(\dot{v} + ur - wp)$$

$$F_z = m(\dot{w} + vp - uq)$$

$$M_x = \dot{p}I_{xx} - \dot{r}I_{xz} + qr(I_z - I_y) - pqI_{xz}$$

$$M_y = \dot{q}I_{yy} + pr(I_{xx} - I_{zz}) + (p^2 - r^2)I_{xz}$$

$$M_z = \dot{r}I_z - \dot{p}I_{xz} + pq(I_{yy} - I_{xx}) + qrI_{xz}$$

Where

$\mathbf{F}=(F_x, F_y, F_z)$  is the external force vector  
 $\mathbf{v}=(U, v, w)\mathbf{T}$  is the velocity vector  
 $\mathbf{M}=(M_x, M_y, M_z)$  is the moment vector  
 $\mathbf{H}$  is the angular momentum vector  
 $\omega=(p, q, r)$  is the angular velocity vector  
 $\mathbf{I}$  is the inertia matrix

The external forces and moment are those generated by the aerodynamic forces, including control surfaces, the propulsion, including control thrusters, and by gravity. The six equations of motion given above are non-linear and coupled. This is further complicated by the fact that the aerodynamic forces are highly non-linear, especially at high angles of attack, and coupled.

The control problem of employing the control actuators in a suitable way to achieve good performance and stability thus becomes a non-linear multivariable control problem. The classical approach to this problem is to linearise around an operating point and then study the control of one variable at a time. There are at least two very severe restrictions to this approach: a missile rarely flies at a trimmed equilibrium, and the states of a missile are normally coupled to each other.

Flight mechanics and controls are treated in many textbooks, e.g. Blakelock. A simplified example of missile control in a 2D, pitch direction case is given in Figure 9.

Nomenclature:

|               |  |
|---------------|--|
| $m$           | Missile mass   |
| $u$           | Missile velocity   |
| $q$           | Dynamic pressure   |
| $d$           | Body diameter  |
| $S$           | Cross section area   |
| $I$           | Moment of inertia  |
| $\ell_0$      | Distance between centre of pressure and centre of gravity            |
| $\ell_t$      | Distance between tail rudder and centre of gravity                   |
| $C_{N\alpha}$ | Aerodynamic derivative, normal force per unit of angle of attack     |
| $C_{N\delta}$ | Aerodynamic derivative, normal force per unit of elevator deflection |
| $C_{mq}$      | Aerodynamic derivative, moment per unit of body rotation rate        |
| $C_{m\alpha}$ | Aerodynamic derivative, moment per unit of angle of attack           |

With variables defined in figure 9 the linearised equations of motion become:

$$\begin{aligned}\ddot{\theta} &= \frac{qS}{I} \left( -\ell_0 C_{N\alpha} \alpha - \ell_t C_{N\delta} \delta + \frac{d^2}{2u} C_{mq} \dot{\theta} \right) \\ \dot{\gamma} &= \frac{qS}{mu} (C_{N\alpha} + C_{N\delta} \delta) \\ \dot{\alpha} &= \dot{\theta} - \dot{\gamma}\end{aligned}$$

The transfer function between velocity vector rotation rate and elevator angle becomes

$$\frac{\dot{\gamma}}{\delta} = k_0 \frac{(1 + \tau_1 s)(1 + \tau_2 s)}{1 + 2\zeta_0 s / \omega_0 + s^2 / \omega^2}$$

With the following values of gain  $k_0$ , eigenfrequency  $\omega_0$  and damping  $\zeta_0$ .

$$\begin{aligned}k_0 &\approx -\frac{qSC_{N\delta}}{mu} \frac{\ell_t - \ell_0}{\ell_0} \\ \omega_0 &\approx \sqrt{\frac{\ell_0 qSC_{N\alpha}}{I}} \\ \zeta_0 &\approx \frac{1}{2u} \left( \frac{I}{m} - \frac{d^2 C_{mq}}{2C_{N\alpha}} \right) \sqrt{\frac{qSC_{N\alpha}}{I\ell_0}}\end{aligned}$$

where it has been assumed that

$$\frac{qSd^2 C_{mq}}{2mu^2 \ell_0} \ll 1$$

These equations show that the fundamental dynamic properties of the missile can vary greatly with velocity, altitude, mass, inertia etc.

The control system should be designed to give the missile sufficient stability and responsiveness for all relevant flight conditions. To design a single controller for all flight conditions is normally not possible. As a consequence many missile controllers use gain scheduling, where a set of operating points are chosen from the set of possible flight conditions. For each of these points the non-linear missile dynamics is linearised and a controller is designed. A scheme for choosing between the controllers, i.e. the gain scheduling, based on some varying parameters such as dynamic pressure and angle of attack is then formulated.

Recent advances in controller design have, however, made it possible to design the controller for all flight conditions at the same time. The currently most promising technique for this is Linear parameter varying (LPV) design, where the plant is assumed to have the form

$$\begin{aligned}\dot{x}(t) &= A(\theta(t))x(t) + B(\theta(t))u(t) \\ y(t) &= C(\theta(t))x(t) + D(\theta(t))u(t)\end{aligned}$$

where  $x$  is the state variable vector,  $y$  is the output,  $u$  is the control input and  $\theta$  is a vector of measured variables. An overview of current issues in missile controller design is found in Ridgely and McFarland.

## Bank-to-turn

Most missiles are roll stabilised in an X or + configuration and use the control actuators to achieve the desired direction of the lateral acceleration. There are, however, missiles where the roll channel has to be given close consideration.

Bank-to-turn guidance requires the missile to manoeuvre with the lateral acceleration in a single body fixed direction. In order to manoeuvre, the missile first has to bank to align the body with the desired direction. Bank-to-turn guidance can be used to decrease the number of control surfaces, and consequently the drag, and can also be required by the propulsion system. Air breathing propulsion such as ramjets can normally only operate under limited variations of angle of attack and can also be sensitive to side slip.

## Trends

Advances in algorithms and computational power will provide missiles with greater manoeuvrability, particularly at high angles of attack, and improved capabilities to optimise the trajectory.

However, the most important trends in the field of guidance and control can be all be described under the label of “integration”:

- Integrated inertial and satellite navigation will provide all sorts of guided weapons with high precision at low cost. Important aspects are the development of small solid state inertial components for use in the automotive industry, and the continuous improvement of the GPS system.
- Integration between guidance and control offers a potential to improve performance. The established division between slower, outer loop guidance and faster, inner loop control can be dissolved using more advanced algorithms.
- Integration between the missile and overall C<sup>4</sup>ISR system will become tighter. High precision targeting can be provided almost in real time. This will enable low cost weapons using precision navigation to attack many targets without using an expensive seeker.

## References

Assarsson A (ed.), *Robotkurs*, Defence Research Establishment, Stockholm, Sweden, 1996. (In Swedish)

Blakelock J H, *Automatic Control of Aircraft and Missiles*, New York: John Wiley and Sons, 1991.

Garnell, P., *Guided Weapon control systems*, Pergamon Press, 1980

Lee, R.G, *Guided Weapons*, London: Brassey’s Defence Publishers, 1988.

Ridgely D B and McFarland M B, “Tailoring Theory to Practice in Tactical Missile Control”, *IEEE Control Systems*, December 1999.

Zarchan P, *Tactical and Strategic Missile Guidance*, Washington, DC: American Institute of Aeronautics and Astronautics, 1994.

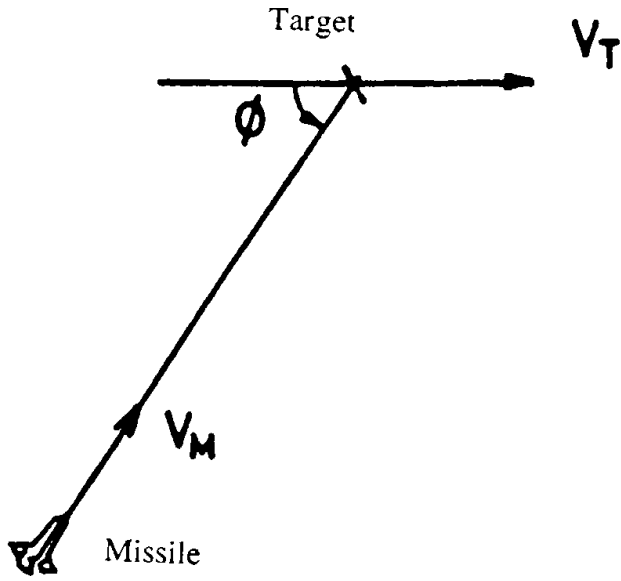

Figure 1. Velocity pursuit kinematics.

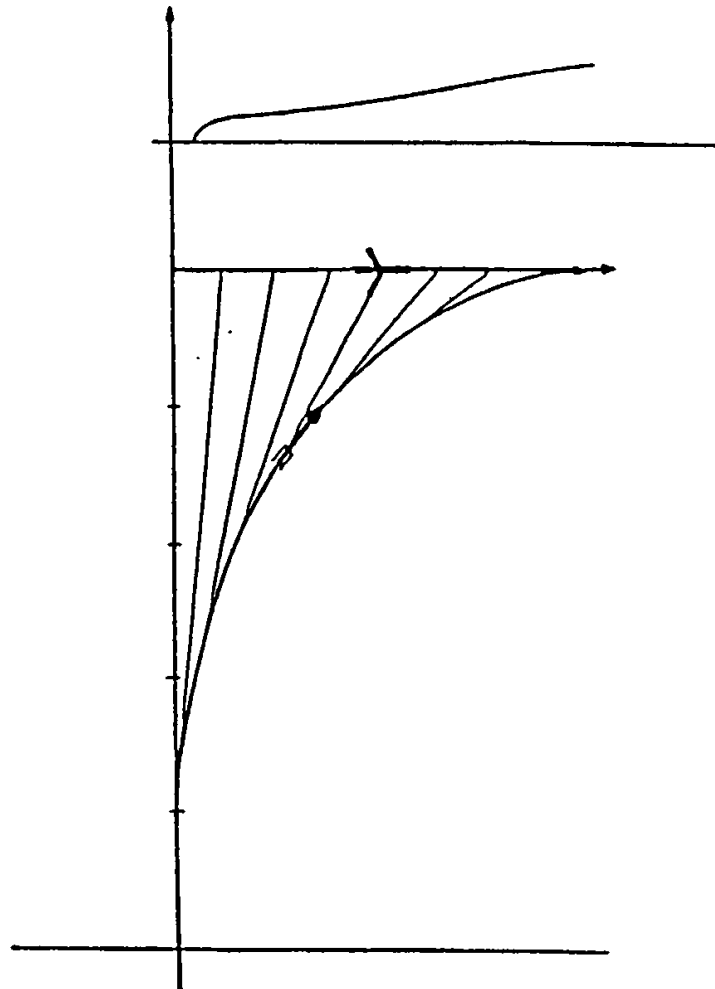

Figure 2. Trajectory and required lateral acceleration for a velocity pursuit missile.  $v_M = 2v_T$ .

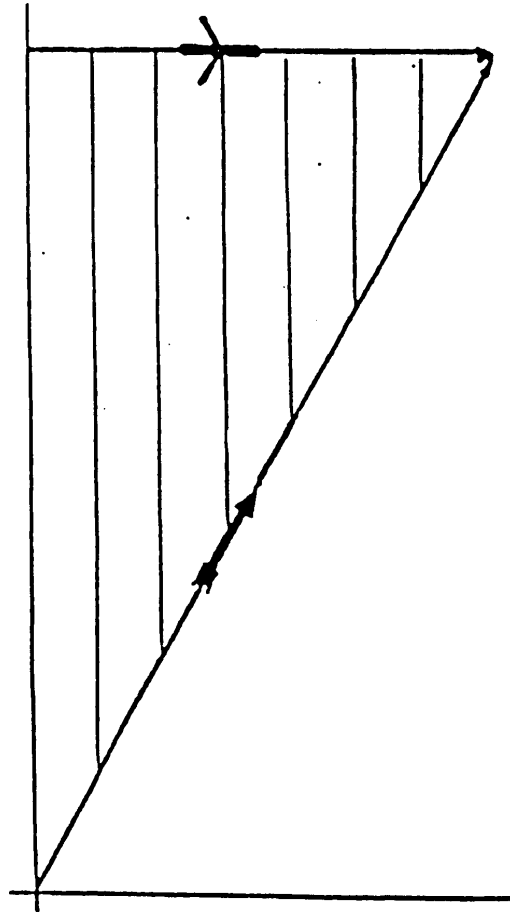

Figure 3. In the ideal collision triangle both the target and the missile move with constant velocity and the bearing to the target is constant throughout the trajectory.

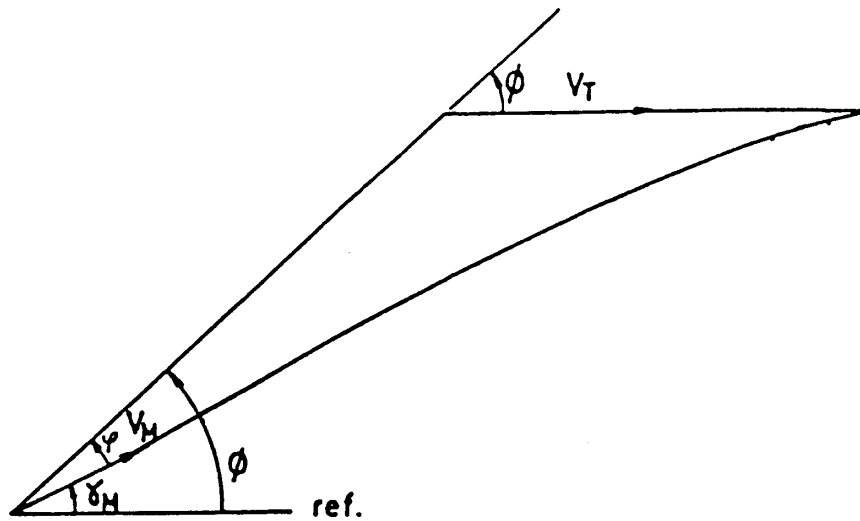

Figure 4. Proportional navigation, kinematics and definition of angles.

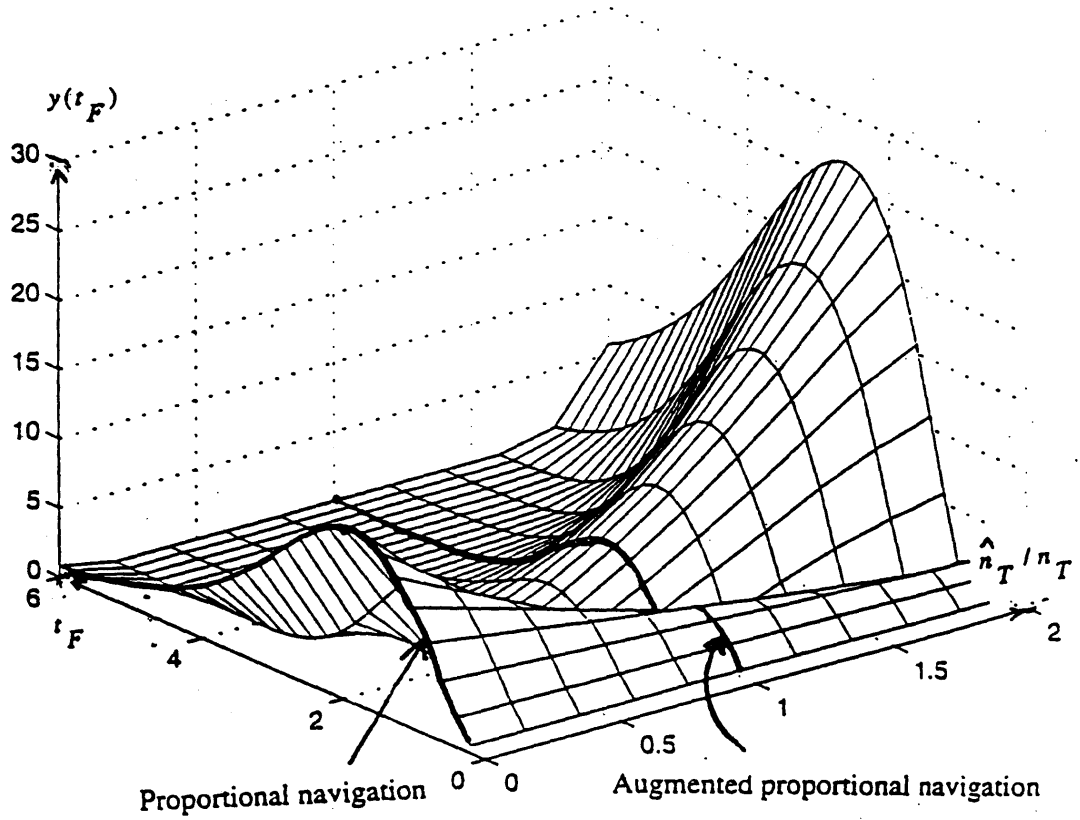

Figure 5. Miss distance in meters as function of time to go at the initiation of the target manoeuvre ( $t_F$ ) and ratio between the estimated target acceleration and the actual acceleration.

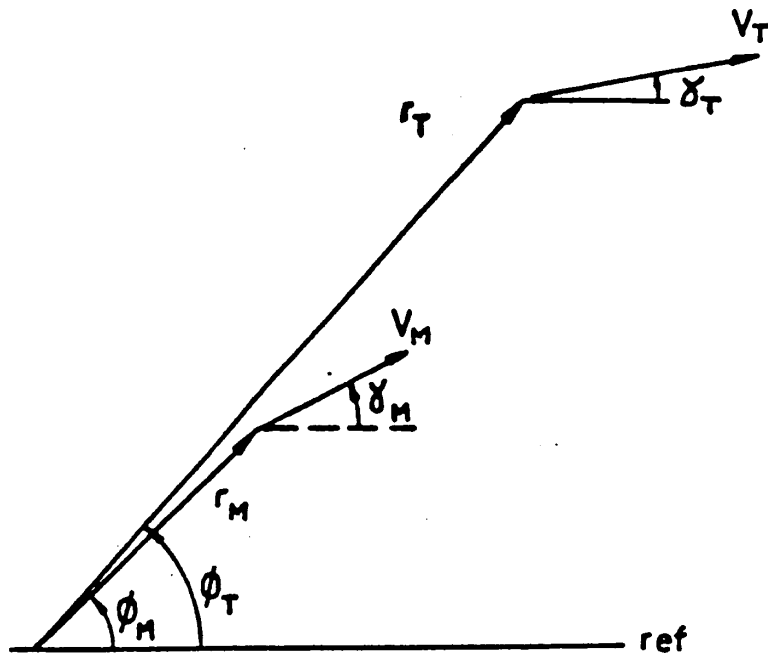

Figure 6. The kinematics of line-of-sight guidance.

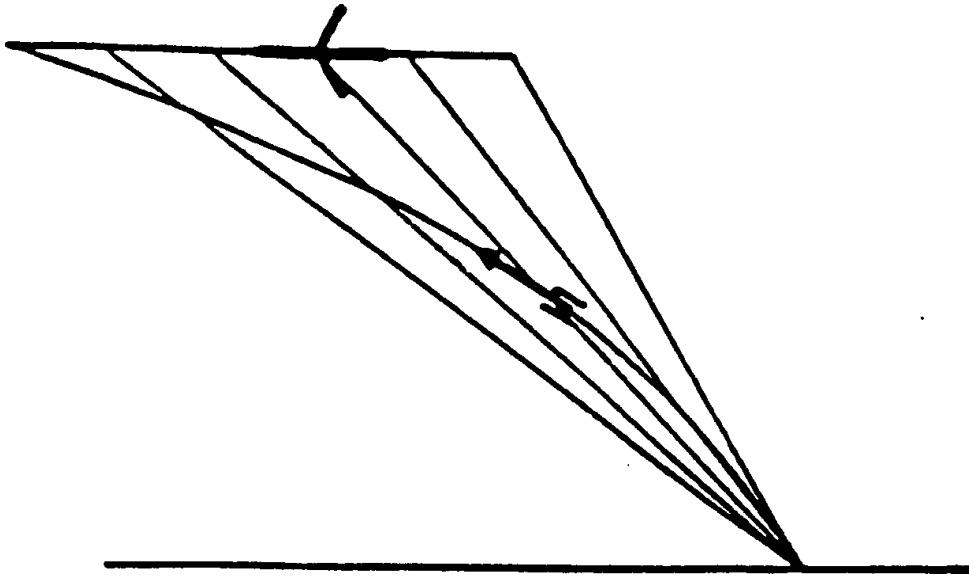

Figure 7. Trajectory of a line-of-sight guided missile.

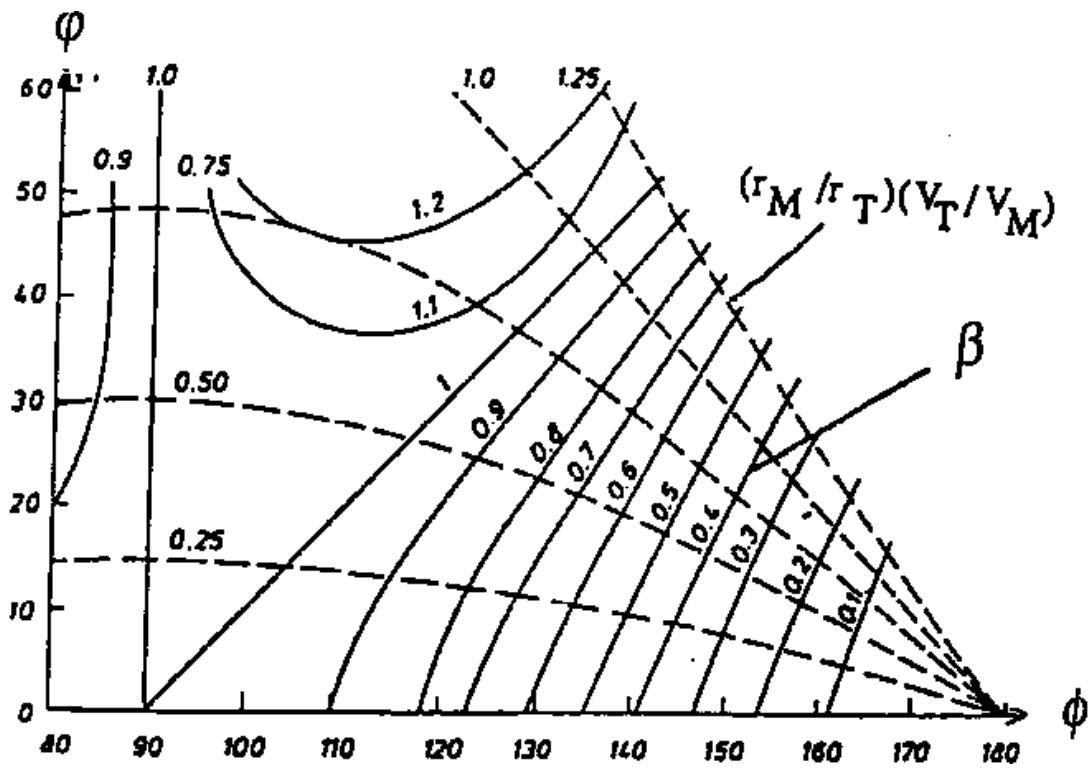

Figure 8. Diagram giving  $\beta$ .

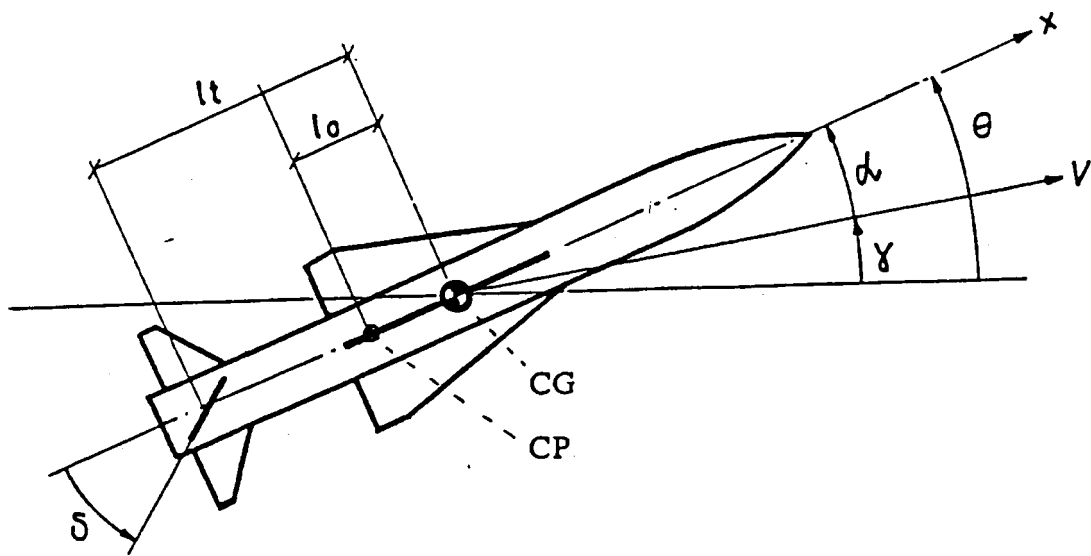

Figure 9. Definitions of variables for the pitch control problem.

**This page has been deliberately left blank**



**Page intentionnellement blanche**